



MESCO Fieldbus MAU Implementation Package

Overview

The MESCO Medium Attachment Unit (MAU) implements the PROFIBUS PA respective Foundation Fieldbus physical layer according to IEC 61158-2. The package enables the design of a 31,25kbps communication for bus powered or external powered Manchester coded devices. It is an ideal solution for Intrinsic Safety (I.S.) devices. The MAU can be used as a functional replacement of the discontinued SIM1 and μSAA22Q ASICs.

Block Diagram

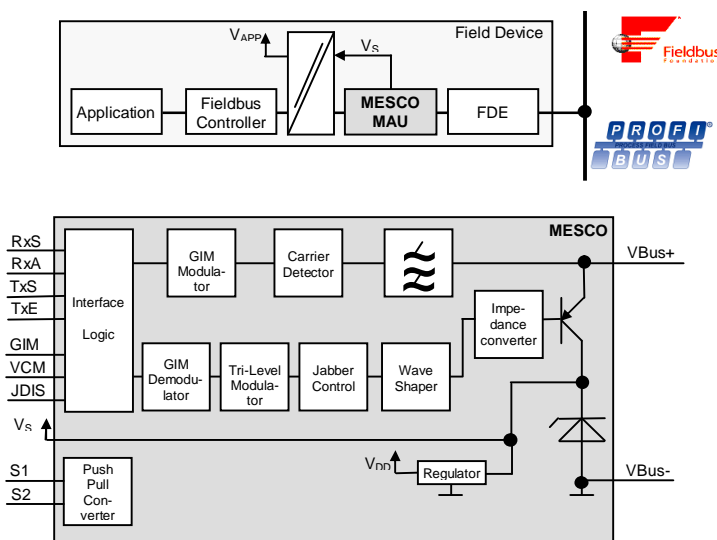

Technology

This MAU supports all send and receive functions as well as the high-impedance decoupling of auxiliary energy from the fieldbus. The impedance converter extracts constant current from the fieldbus and modulates the current during transmission. Two stabilized voltage supply outputs are available. The MAU allocates all signals for the standard MDS-MAU interface described in IEC 61158-2. It can be directly connected to a field bus controller like FIND1+(Yamaha) or SPC 4-2(Siemens). The design is optimized for low power consumption and easy implementation of Intrinsic Safety. The circuitry is build with standard components and therefore totally under control of the user. No dependence on ASIC supplier.

Referencing to the ISO-OSI-model this medium attachment unit allows the implementation of layer 1.

Technical Data

- MAU according to IEC61158-2
- Type 1: 31,25 kbit/s voltage mode
- Bus voltage range 9...32VDC
- Adj. constant current 10...30mA
- Low current consumption 2mA
- Supply output 6,4VDC +/- 3%
- Standard MDS-MAU interface
- 5V tolerant logic levels
- Jabber detect and inhibit
- Fault disconnect equipment (FDE)
- Operating temperature -40...+85°C
- Dimensions 8,4 cm² (29x29 mm)
- DC-DC-Converter output
- Current saving galvanic isolation Interface compatible with SPC4-2
- Suitable for I.S. applications
- Lead-free design

Related services

- Redesign of existing hardware
- Implementation on custom designs
- Hardware-/software engineering for PROFIBUS PA and Foundation Fieldbus devices
- Support IS approval process

Delivery Content

- Circuit schematic
- Bill of Material (BOM)
- Design documentation
- Test documents
- 1 Evaluation module of the MAU
- 1 day support for implementation



Order Information

No. 42000